



74 cm - 89 cm



by  ALBINI & FONTANOT®

English

ASSEMBLY INSTRUCTIONS

KOMPACT



Ø 8x300 12x120 14x150 18x120 mm

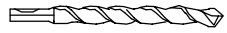

Ø 4.5 8.5 mm

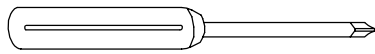

PH 2

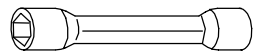

10-13-17 mm

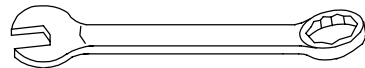

13-17-22 mm



2.5-3-5-6 mm

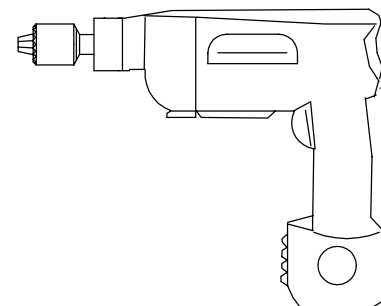
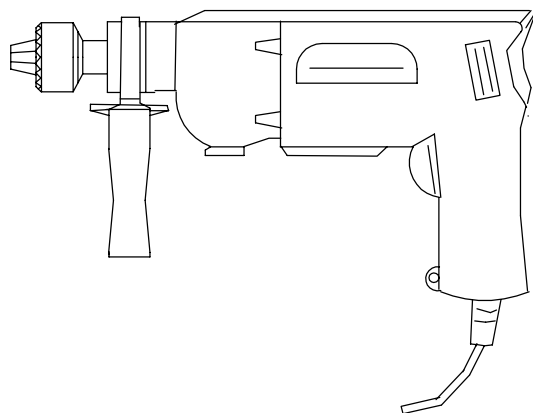
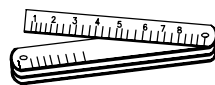
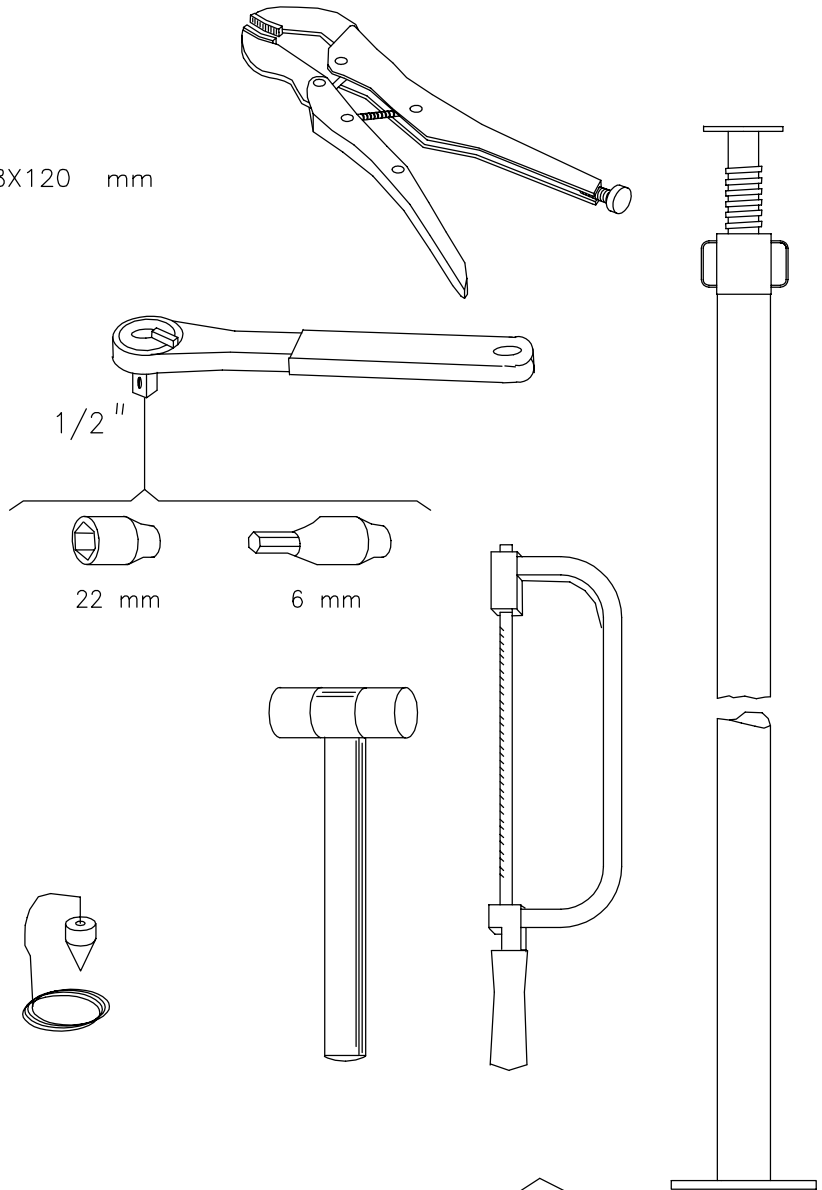

In order to proceed with the assembly, unpack all stair components and lay them out on a sufficiently large surface. Check all components for quantity, comparing with the list in TAB.1 (A = Code, B = Quantity). In the packing box you will find a videocassette showing the assembly. We suggest watching it before proceeding with the assembly.

Assembly

1. Measure carefully the floor-to-floor height (H) (FIG.2).
2. Calculate the height of the Rise:
deduct 20.5 cm (height of the first rise) from the floor-to-floor height (H);
divide the result by the number of rises - 1 (divide by the number of treads, as the last rise is given by the distance between the last tread and the landing floor).
Example (FIG.2): with a floor-to-floor height of 300 cm and a staircase with 13 rises (i.e. with 12 treads): $(300 - 20.5 / 13 - 1) = 23.29$ cm.
3. Measure carefully the ceiling opening (C) (FIG.2).
4. Calculate the measure of the Going (P).
With the version of the staircase L=74 (railing included) as in FIG.2A the calculation is the following:
a) Deduct from the measure (C) of the ceiling opening the following steady measures: 1) 29 cm (= depth of the last tread); 2) 69 cm (= angle treads); 3) 1 cm (distance from the wall).
b) Divide the result by the number of the remaining treads. Example: with a ceiling opening measure of 228 cm and a staircase as in FIG.2A, the calculation is the following: $228 - 29 - 69 - 1 / 6 = 21.5$ cm (= measure of the going).
With the version of the staircase L=89 (railing included) as in FIG 2B the calculation is the following:
a) Deduct from the measure (C) of the ceiling opening the following steady measures: 1) 33 cm (= depth of the last tread); 2) 84 cm (= angle treads); 3) 1 cm (distance from the wall).
b) Divide the result by the number of the remaining treads. Example: with a ceiling opening measure of 262 cm and a staircase as in FIG.2B, the calculation is the following: $262 - 33 - 84 - 1 / 6 = 24$ cm (= measure of the going).
5. (see FIG.3) – assemble the elements N24 to the supports N21, N22.
Set the measure of the going : for the straight treads (see measure -P- in FIG.3) the going will have the measure calculated in 4. For the angle treads (see -P- in FIG.2) the going has a constant measure of:
20 cm (FIG 2A) for the version L=74 (railing included)
24 cm (FIG 2B) for the version L=89 (railing included)
Tighten finally the screws B07. Fit the tubes C21 into the internal part of the elements N24, the threaded bars C22, the flat washers C20 with the knurled surface towards the support flange, the nuts B99. Fit the element N25 into the support N22 of the 2nd tread, until the end.
6. (see FIG.5) + (FIG.1) – determine the drilling point on the ceiling in line with the holes in the plate of the final support N20. Drill with drilling bit \varnothing 18 mm.
7. (see FIG.7) + (FIG.1) – fit the pieces C13 and B02 into the elements F23. Fit the elements F23 together with the articles C57 on level with the fore edge of the treads L25. Drill 30 mm deep with bit \varnothing 4.5
8. (see FIG.4) + (FIG.5) – fit the final support N20 to the ceiling by using the pieces C48, without tightening. Assemble the tread L25 to the supporting element N20 by using the articles C53. Check the horizontal position of the tread and tighten the articles C48. Apply D34 part, in order to cover the plate, with parts B12 and C62, drilling with \varnothing 8 mm.
9. Fit an intermediate support N21 into the final support N20. Fasten it below by means of a self-blocking clamp before tightening. Assemble the tread by using the articles C53. (As you proceed with the assembly of supports and treads, it is necessary to prop-up the supports with a mechanical steel prop, so that the ceiling will not have to bear too much weight). It is necessary to put a piece of wood under every 4 to 5 supports and it is strictly forbidden, for safety reasons, to get on the stair before having fixed it to the floor (point 13) and strengthen it (point 14). Adjust the height of the rise that you have calculated in point 2; check the horizontal position of the tread and the alignment with the tread previous tread. Tighten finally the pieces B99 by both side of the support, in order to avoid that the tread is to be modified in its trim (horizontality and verticality) . Proceed in the same way with the assembly of the remaining intermediate supports N21. On the angle treads (see FIG.8) it is necessary to carry out the drillings for connection with the supporting element, according to the chosen winding direction (drill with drilling bit \varnothing 8,5 mm for a depth of 30 mm).
10. (see FIG.9) – Fit the elements F23 onto the internal side of the angle treads L26, L27, L28 by using the elements C57 (drill with drilling bit \varnothing 4.5 mm for a depth of 30 mm). To determine the position, use a baluster C03 as a vertical guide reference.
11. (Fit the supporting elements N22 and N23 onto the support N21. Assemble the treads by using the articles C53. Set the measure for the height of the rise calculated at point 2. Unscrew the element N25 until it touches the floor.

- Check the horizontal position and the alignment with the previous tread; then tighten finally the articles B99.
12. Check for vertical position of the whole staircase and, if necessary, adjust by shifting the support N23.
 13. Unscrew the first tread and drill the floor with drilling bit \varnothing 14 mm, using as reference the holes of the support base N23 (see FIG.1). Insert the screws C47 and tighten finally.
 14. (see FIG.15) – Reinforce the staircase on the following places: a) at an intermediate level of the staircase position the pole G08 to the floor, by using the articles D31, C35 et B20. – b) connect the staircase to the wall by using the element F12 together with the articles B13 (drill with drilling bit \varnothing 14 mm) and C57 (drill with drilling bit \varnothing 4.5 mm) strictly in the shown points. Cover with the element B95.

Assembly of the railing

15. (see FIG.6) – Fit the elements B65, C59, C54 into the balusters C03 by using the tube B68 to hammer in.
16. Fit the elements F23 onto the straight treads by using a baluster C03 in order to determine the ideal position. Pierce with drilling bit \varnothing 4.5 mm for a depth of 30 mm.
17. Insert the connecting balusters C03 between the treads. Position the balusters in a way, that the holes of the fixing element B65 be turned upwards as in FIG.6. Tighten the articles B02 shown in FIG.7.
18. (see FIG.1) – Fit the reinforcing element F07 to the first bottom baluster. Fix to the floor, beneath the first baluster C03, the element F01, drilling with bit \varnothing 8 mm. Use the fixing elements C58, B12, B02.
19. Custom cut the handrail segments A11 (fig.10); assembly them with article B51(fig.11).In order to obtain a perfect fitting, the handrail must do about an 1/8 rotation from the contact point, to the alignment point of the lower slots (fig.12); if that does not happen, turn enough the thread element of the handrail, screwing it, with elements B44 and B35 (fig.13).Fix the element A09 with article C43 (fig.1).
20. Connect the handrail to the balusters, by means of the article B49. Check the vertical position of the balusters.
21. Cut the intermediate balusters C03 to a length that has to be measured on the railing.
22. Insert the intermediate balusters C03. Position the balusters in a way, that the holes of the fixing element B65 be turned upwards as in FIG.14. Tighten the articles B02.
23. Connect the balusters to the handrail by means of the article B49. Check the vertical position of the balusters.
24. (see FIG.14) – In order to reinforce the railing it is necessary to use the following elements :
 - a) – see drawing FIG.14, below – connect together two balusters by using the elements F08, C49, C50 and a piece of tube C03.
 - b) – see drawing FIG.14 above – connect a baluster to the wall by means of the article F09 together with the pieces F08. Drill with drilling bit \varnothing 8 mm and use the articles C49, C50, C58, B12.
25. (see FIG.14) Complete the assembly of the railing by fitting the pieces B82 to the bottom of the balusters.
26. (see FIG.1) – Fit onto the supporting elements the lower closing lids D27, D28, D29.
27. (see FIG.1) – Fit onto the supporting elements the lateral closing lids D30, proceeding as follows :
 - a) – hook the back side of the lid onto the curved side of the support.
 - b) – press the lid to the metal sheet, until the two elastic hooks spring into the holes.

TAB. 1

A	B			
	K35001	K35023	K35016	K35026
	K35002	K35024	K35017	K35027
	K35003	K35025	K35018	K35028
A09	6		6	
A11	4		3	
B02	34		30	
B06	22		22	
B07	22		22	
B12	8		8	
B13	2		2	
B20	3		3	
B23	22		22	
B35	1		1	
B44	1		1	
B49	40		30	
B51	4		3	
B65	20		15	
B68	1		1	
B82	20		15	
B95	4		4	
B99	44		44	
C03	20		15	
C13	29		25	
C20	44		44	
C21	22		22	
C22	22		22	
C35	1		1	
C43	6		6	
C47	3		3	
C48	2		2	
C49	6		6	
C50	6		6	
C53	48		48	
C54	20		15	
C57	64		56	
C58	8		8	
C59	20		15	
D27	10		10	
D28	11		11	
D29	11		11	
D30	22		22	
D31	1		1	
F01	2		2	
F07	1		1	
F08	12		12	
F09	2		2	
F12	2		2	
F23	29		25	
G08	1		1	
L25	9		6	
L26	1		2	
L27	1		2	
L28	1		2	
N20	1		1	
N21	9		9	
N22	1		1	
N23	1		1	
N24	11		11	
N25	1		1	

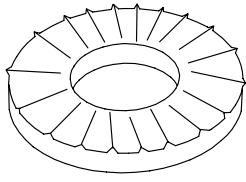

C20

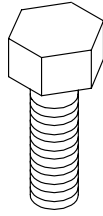

B07

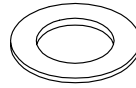

B06



B23

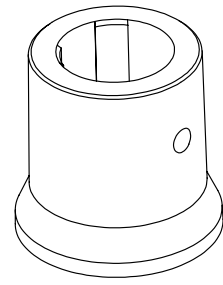

F01



B02

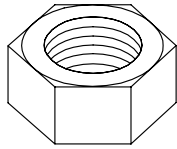

B99

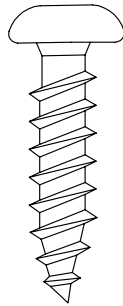

C53

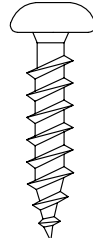

C57

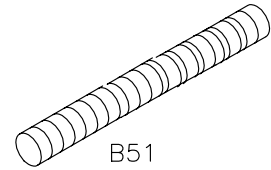

B51

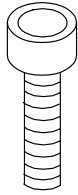

C50



C49

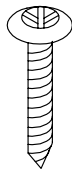

B49



C54

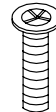

C59

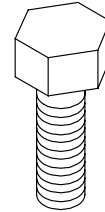

B44

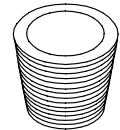

B35

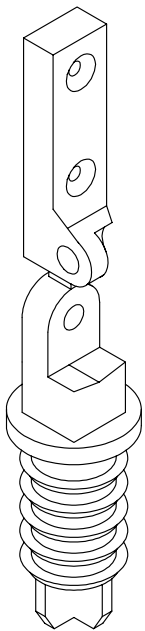

B65

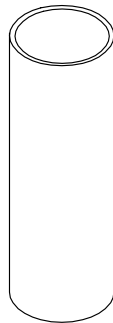

B68

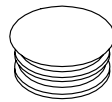

B82



C13

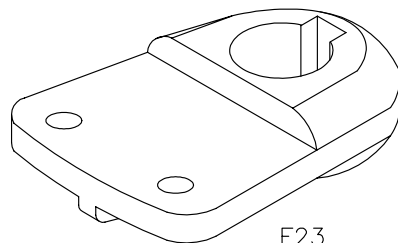

F23

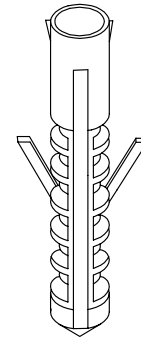

B12

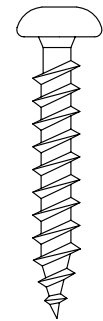

C58

FIG. 1

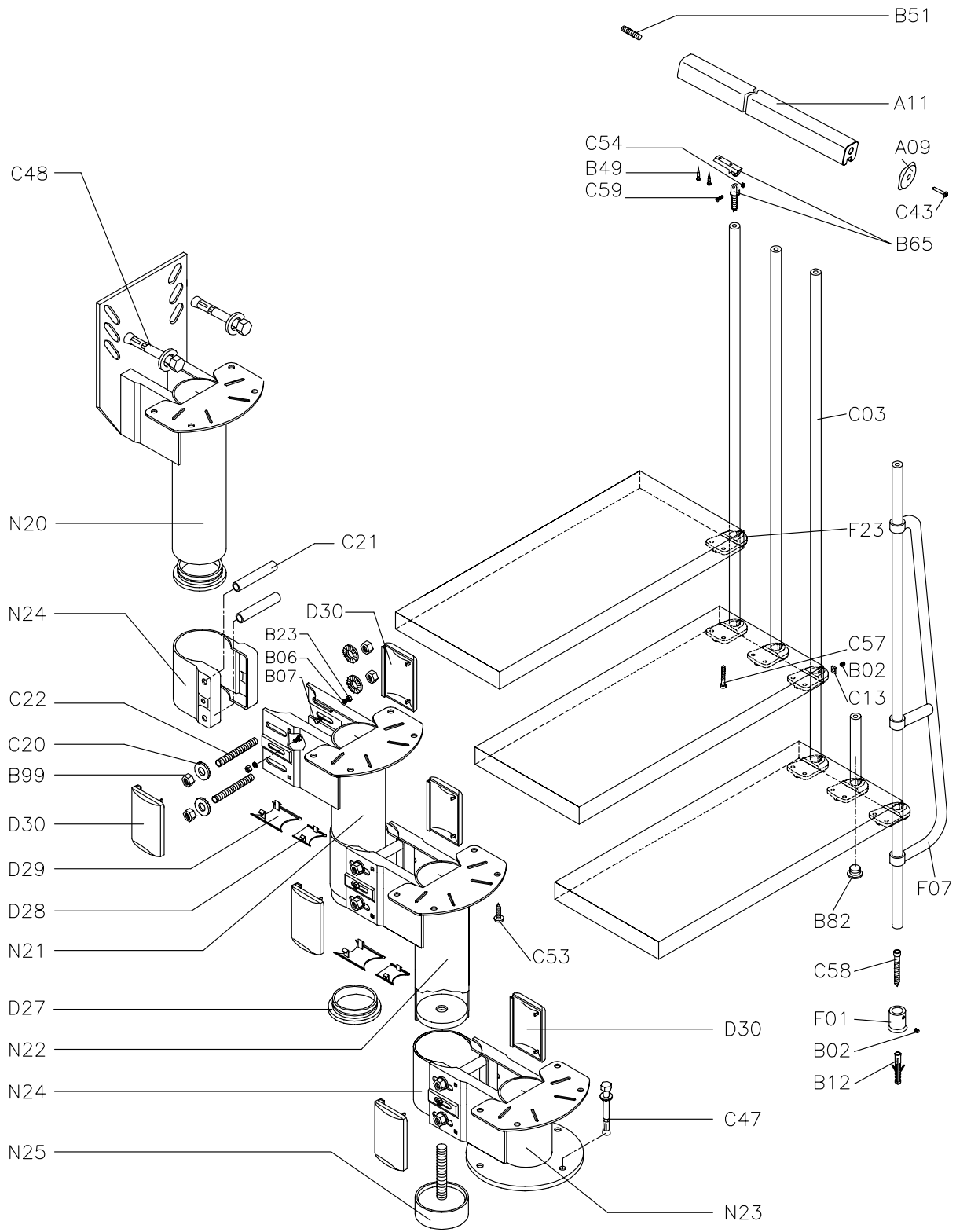
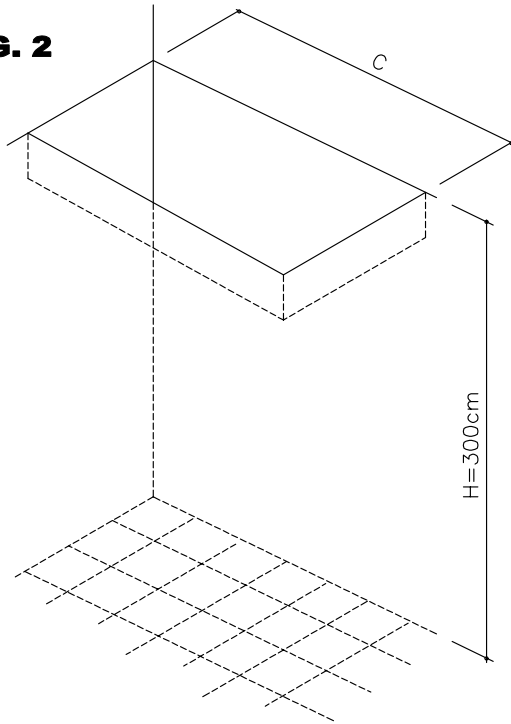

FIG. 2



SIEHE UMFANG DER KONFIGURATIONEN
LOOK AT THE CONFIGURATION OVERALL SPACE
CONSULTEZ L'ENCOMBREMENT DES CONFIGURATIONS
VEDI INGOMBRO CONFIGURAZIONI

TAB.2
TAB.3
TAB.4
TAB.5

FIG. 2A

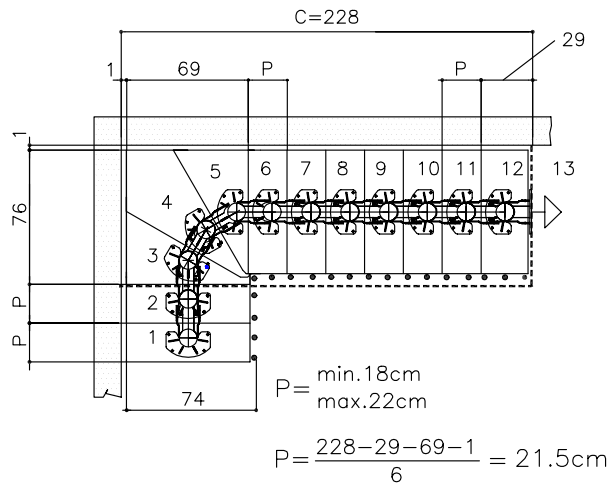

FIG. 2B

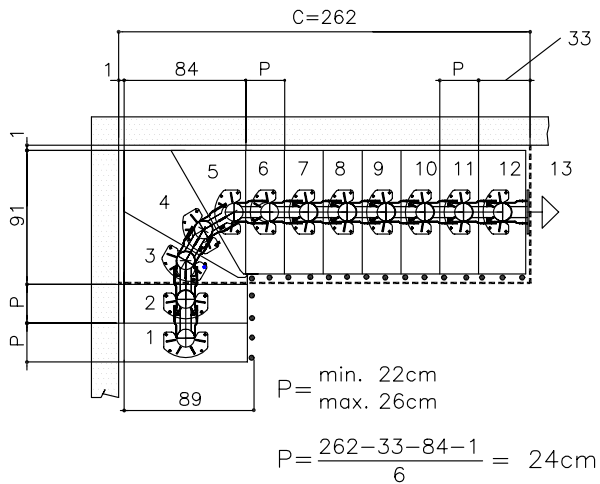

FIG. 3

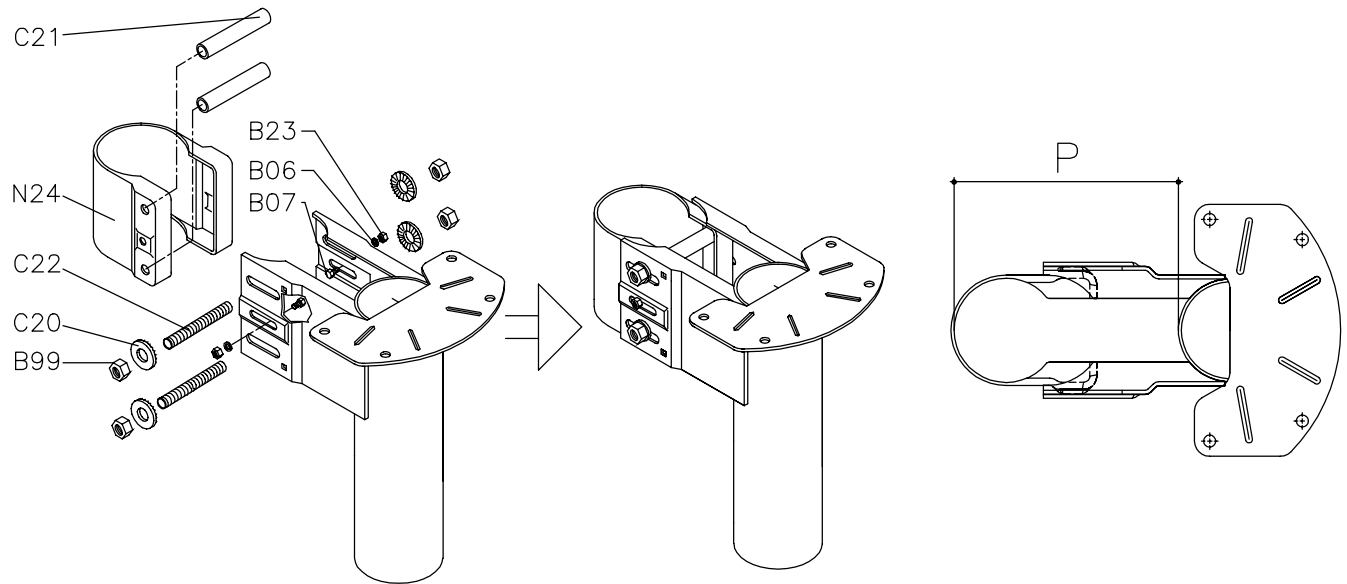

FIG. 4

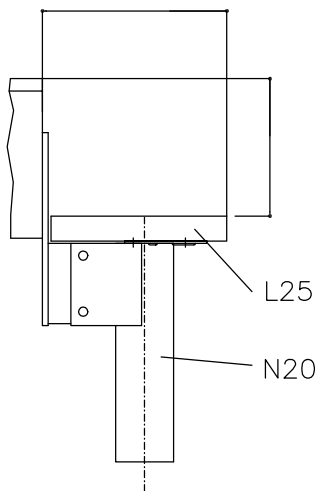

FIG. 5

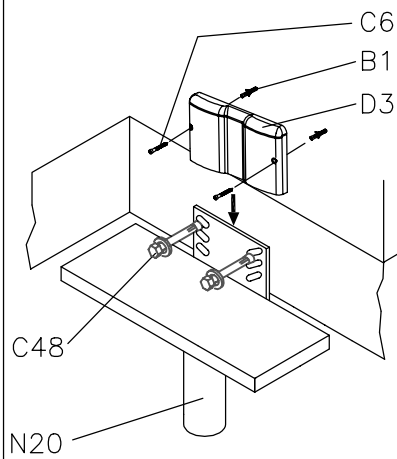

FIG. 6

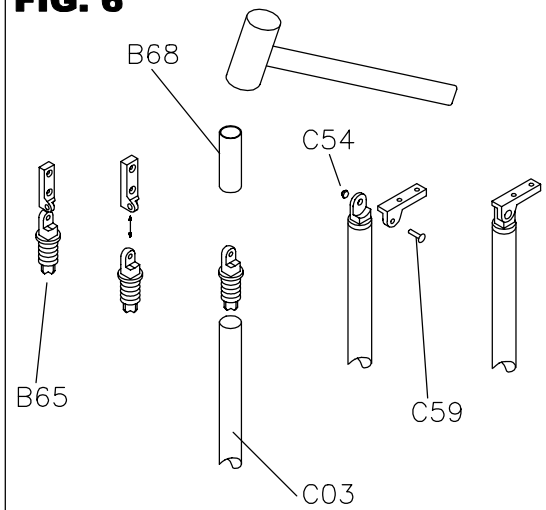

FIG. 7

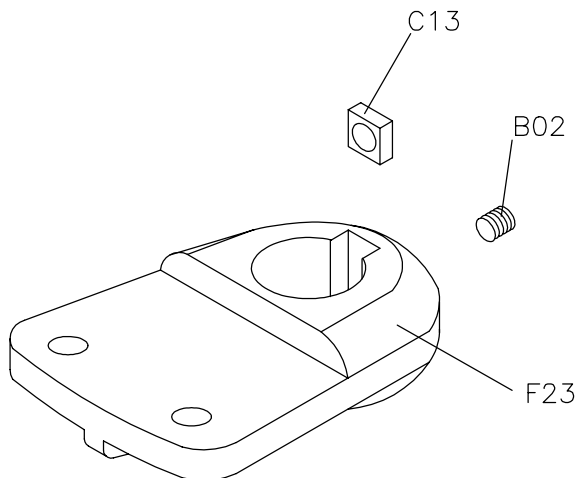

FIG. 8

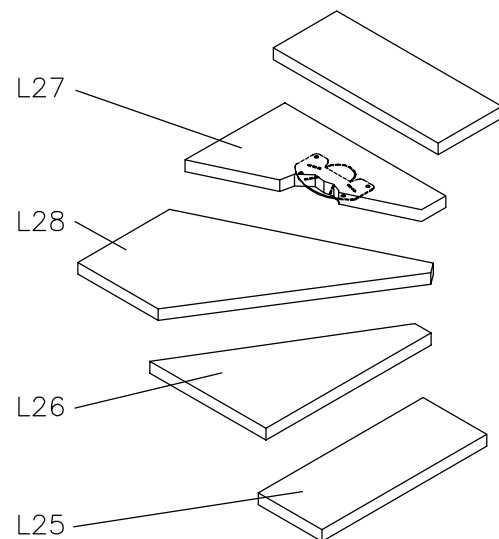

FIG. 9

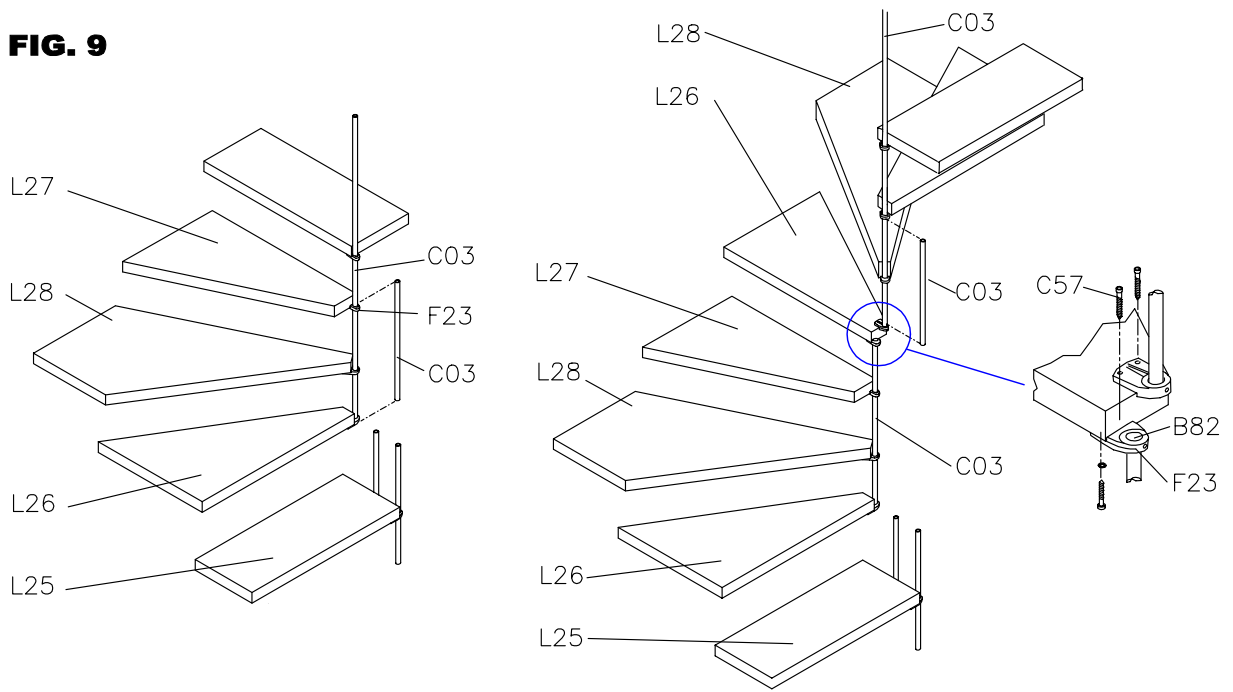

FIG. 10

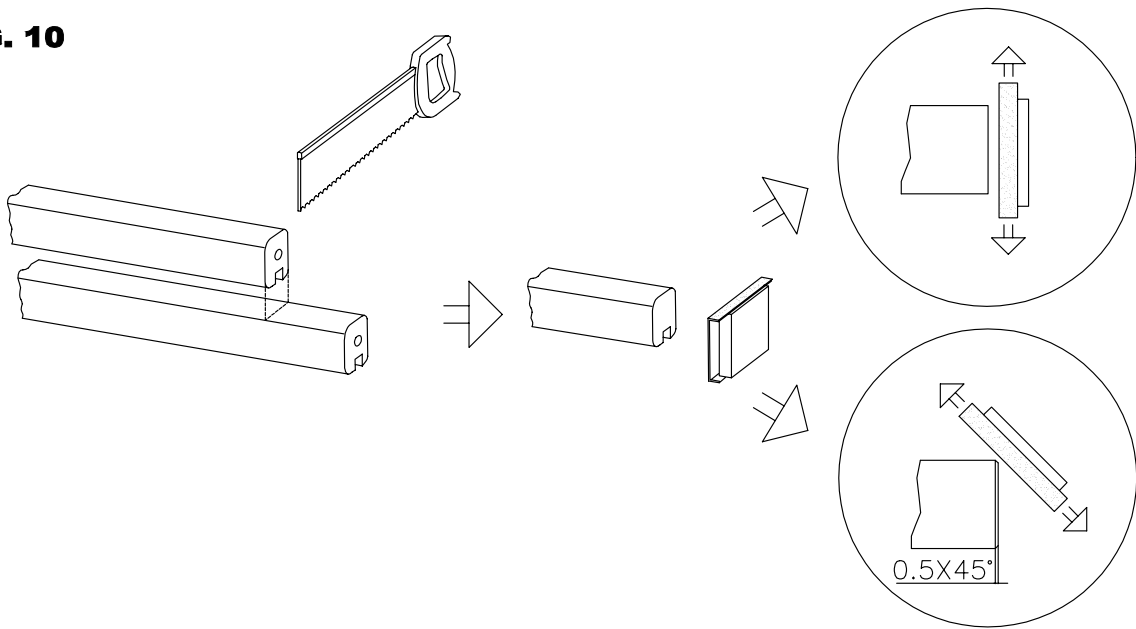

FIG. 11

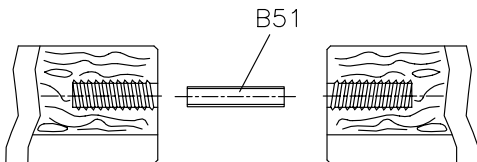

FIG. 12

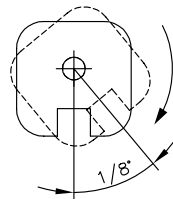

FIG. 13

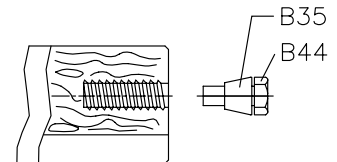

FIG. 14

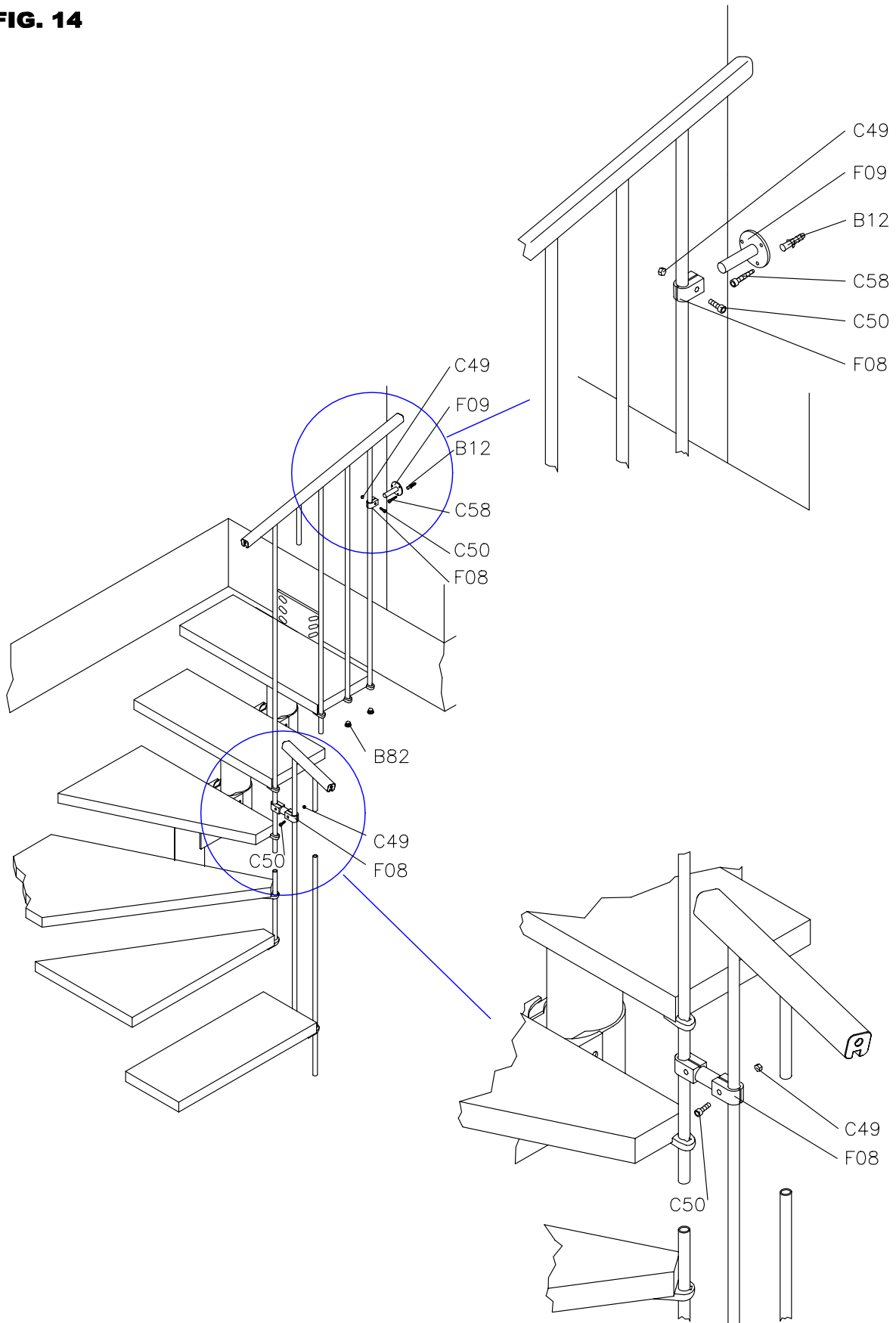
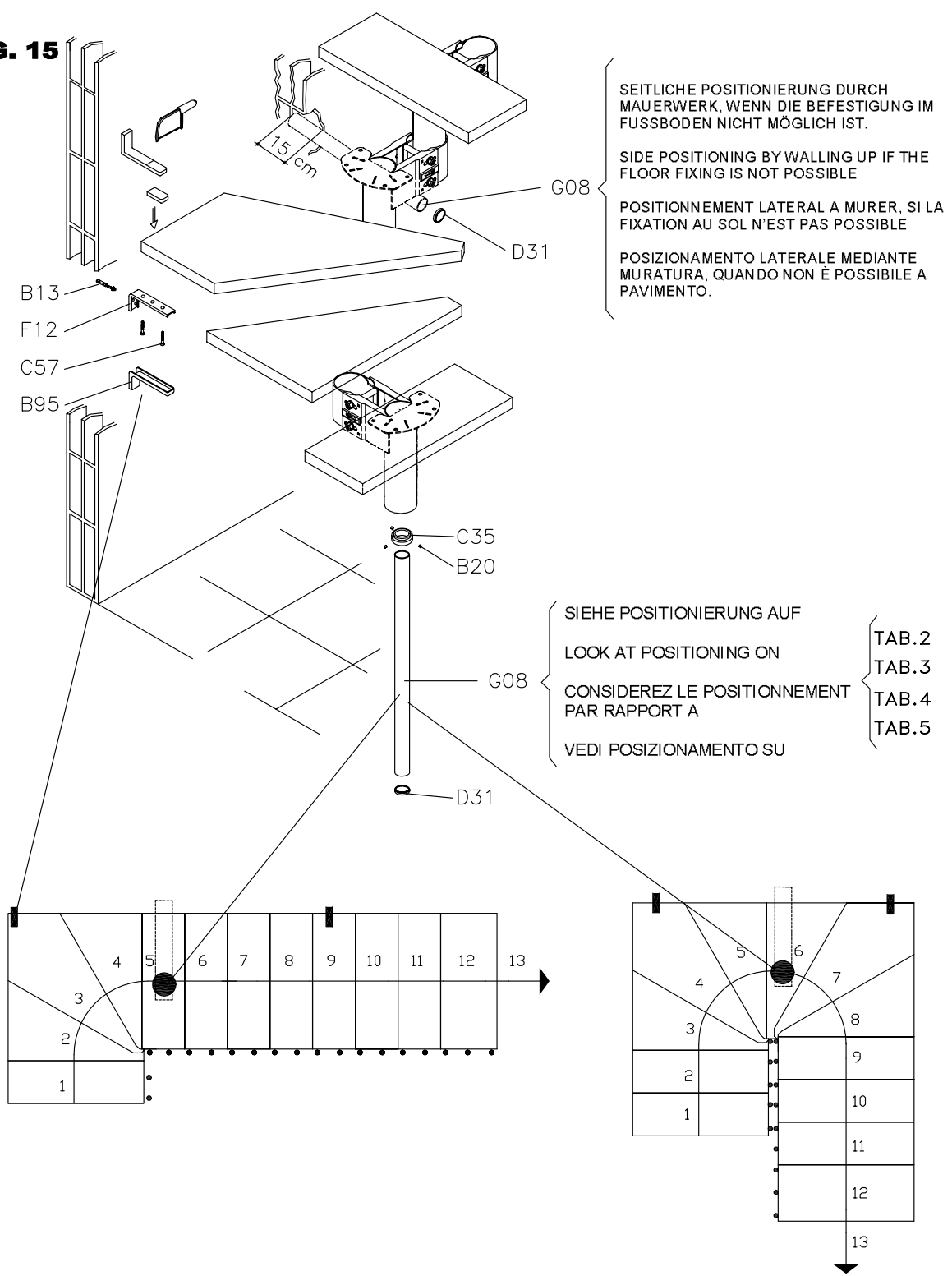

FIG. 15



- K35001
- K35002
- K35003
- K35023
- K35024
- K35025

- K35016
- K35017
- K35018
- K35026
- K35027
- K35028

KIT GELÄNDER AUSSEN-SEITE (bestehend aus 5 Geländersäulen, Handlauf und Befestigungen). In der Zeichnung hierunter kann man die Anzahl der erforderlichen Geländerstäbe für die Aussenseite zählen, die bei einer Gestaltung dieser Art in Frage kommen. (Die Geländerstäbe sind auf der Zeichnung mittels der schwarzen Punkte und der Zahlen auf der Aussenseite angegeben).

KIT EXTERNAL RAILING (composed of 5 balusters, handrail and fixings). From the following drawing it is possible to determine the necessary number of balusters on the external side of the staircase, taking into account the chosen configuration (the balusters are represented by the figures and dots visible on the external side)

KIT BARANDILLA EXTERIOR (compuesto por 5 barrotes, el pasamanos y las fijaciones). El siguiente dibujo nos permite saber el número de barrotes necesarios, en el lado exterior de la escalera, según la configuración elegida (los barrotes están representados por los números y por los puntos en el lado exterior).

KIT GARDE-CORPS EXTERIEUR (composé de 5 colonnettes, main-courante et fixations). Dans le plan ci-dessous il est possible de compter le nombre de colonnettes nécessaires, sur le coté extérieur de l'escalier, en considérant la configuration choisie (les colonnettes sont représentées par les chiffres et par les points sur le coté extérieur)

KIT RINGHIERA ESTERNA (composta da 5 colonnine, il corrimano e i fissaggi). Nel disegno che segue è possibile contare il numero di colonnine necessarie, sul lato esterno della scala, considerando la configurazione scelta (le colonnine sono rappresentate dai numeri e dai punti sul lato esterno).

KIT BUITENBALUSTRADE (bestaande uit 5 spijlen, handgreep en bevestigingsmiddelen) Het plan hieronder maakt het U mogelijk het aantal spijlen te tellen dat U nodig heeft aan de buitenzijde van de trap, rekeninghoudend met de door U gekozen configuratie.
(de spijlen zijn aangeduid met cijfers en zwarte punten aan de buitenzijde van de trap.)

BALUSTRADA ZEWNĘTRZNA (kpl. złożony z 5 tralek, poręczy oraz łączników). Na podstawie załączonego rysunku możliwe jest zliczenie ilości tralek potrzebnych na zewnętrzną stronę schodów, biorąc pod uwagę wybraną konfigurację (ilość tralek wyrażona jest liczbami oraz punktami widocznymi po zewnętrznej stronie schodów)

KIT DE GRADE PROTECÇÃO EXTERIOR (composto de 5 colunas, corrimão e fixações). No esquema abaixo é possível contar o numero de colunas necessárias, sobre o lado exterior da escada, considerando a configuração escolhida (as colunas estão representadas pelos algarismos e pelos pontos no lado exterior).

KIT OGRADA S VANJSKE STRANE STEPENICA (Sastoji se od 5 stupića, rukohvata i elemenata za spajanje) Na crtežu koji slijedi moguće je izbrojiti potrebnu količinu stupića s vanjske strane stepenica, uzimajući u obzir konfiguraciju istih (stupići su označeni brojem i točkicama s vanjske strane ograde stepenica)

KIT OGRAJA Z ZUNANJE STRANI STOPNIC (Sestavljena je iz 5 stebričkov, dr`ala in elementov za spajanje) Na naslednji sliki lahko preštejete potrebno količino stebričev na zunanji strani stopnic, upoštevajoč njihovo konfiguracijo (stebriči so z zunanje strani ograje stopnic označeni s številkami in pikami).

SAMLESÆT UDVENDIGT GELÆNDER (det indholder 5 søjler, håndlisten og fikseringer). På den efterfølgende tegning kan man regne det antal søjler ud, man har brug for til den yderste del af trappen, alt efter den valgte konfiguration (søjlerne repræsenteres ved de tal og de punkter, som findes på den ydersiden).

KIT EXTERN RÄCKE (består av 5 ståndare, handledare och fästen). På teckningen som följer är det möjligt att utläsa antal ståndare som behövs på den externa sidan av trappan med hänsyn tagen till den valda formen (ståndarna är representerade av nummer och punkter på den externa sidan).

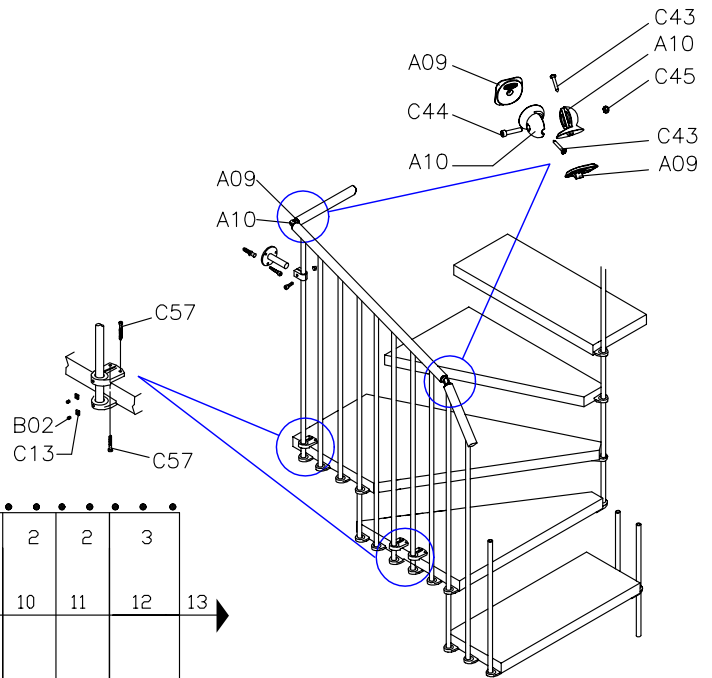
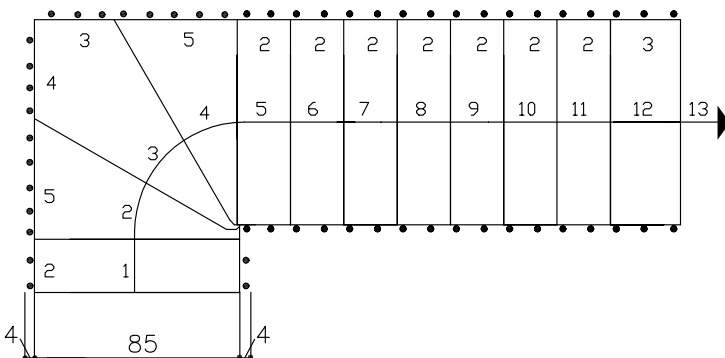
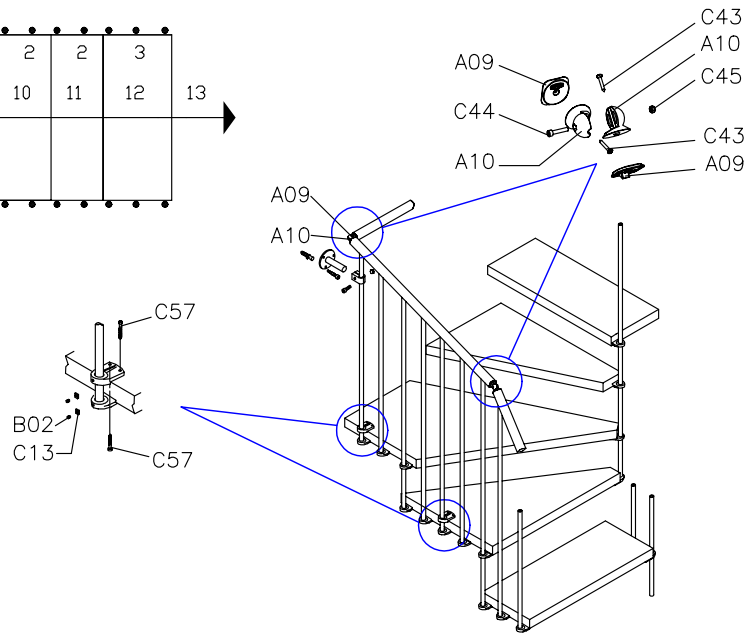
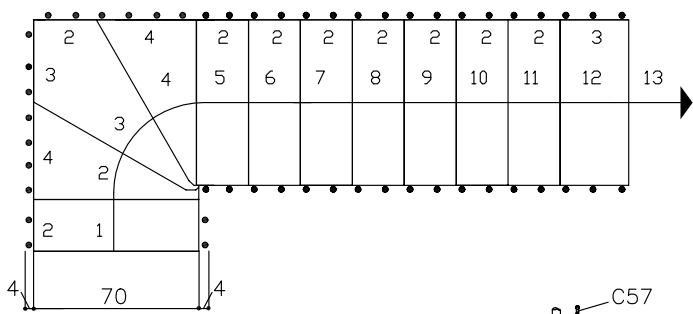

TAB. 2

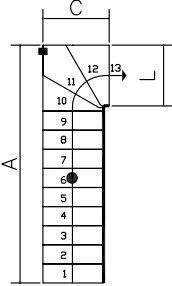
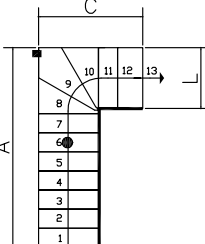
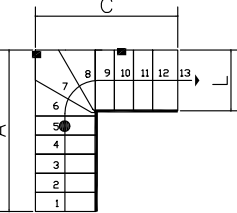
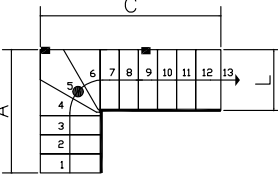
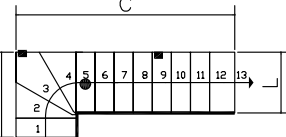
	cm			cm		
	L=74	L=89		L=74	L=89	
	A	238÷274	289÷325	A	220÷252	267÷299
	B			B		
	C	78	94	C	98	117
	A	202÷230	245÷273	A	184÷208	223÷247
	B			B		
	C	116÷120	139÷143	C	134÷142	161÷169
	A	166÷186	201÷221	A	148÷164	179÷195
	B			B		
	C	152÷164	183÷195	C	170÷186	205÷221
	A	130÷142	157÷169	A	112÷120	135÷143
	B			B		
	C	188÷208	227÷247	C	206÷230	249÷273
	A	94÷98	113÷117	A	76	91
	B			B		
	C	224÷252	271÷299	C	242÷274	293÷325

TAB. 3

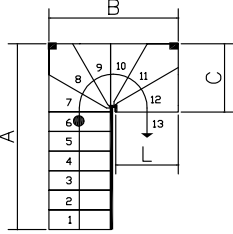
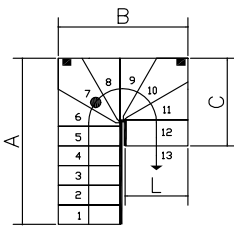
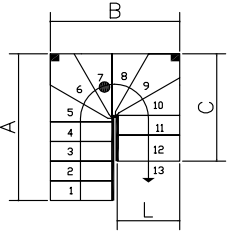
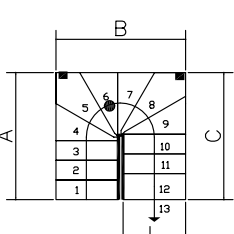
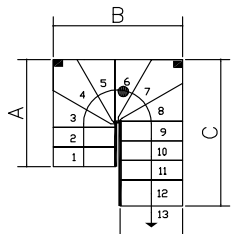
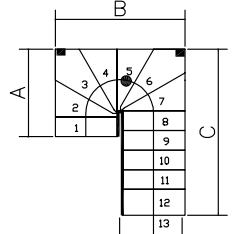
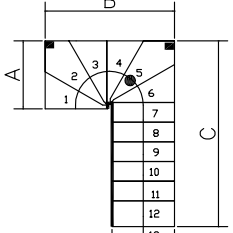
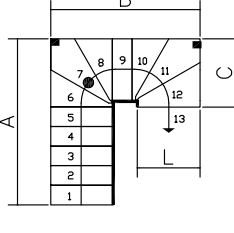
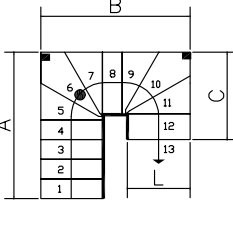
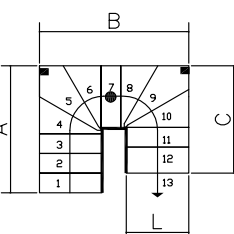
	cm			cm			
	L=74	L=89		L=74	L=89		
	A	184÷208	223÷247		A	166÷186	201÷221
	B	145	175		B	145	175
	C	78	94		C	98	117
	A	148÷164	179÷195		A	130÷142	157÷169
	B	145	175		B	145	175
	C	116÷120	139÷143		C	134÷142	161÷169
	A	112÷120	135÷143		A	94÷98	113÷117
	B	145	175		B	145	175
	C	152÷164	183÷195		C	170÷186	205÷221
	A	76	91		A	166÷186	201÷221
	B	145	175		B	163÷167	197÷201
	C	188÷208	227÷247		C	78	94
	A	148÷164	179÷195		A	130÷142	157÷169
	B	163÷167	197÷201		B	163÷167	197÷201
	C	98	117		C	116÷120	139÷143

TAB. 4

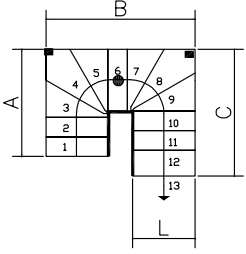
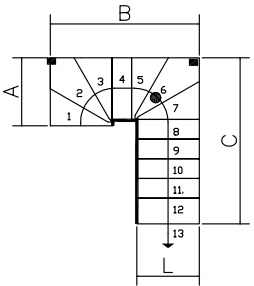
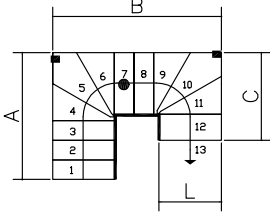
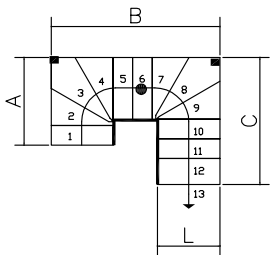
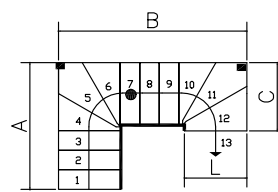
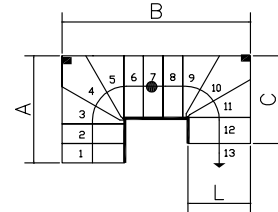
	cm			cm		
	L=74	L=89		L=74	L=89	
	A	112÷120	135÷143	A	94÷98	113÷117
	B	163÷167	197÷201	B	163÷167	197÷201
	C	134÷142	161÷169	C	152÷164	183÷195
	A	76	91	A	148÷164	179÷195
	B	163÷167	197÷201	B	181÷189	219÷227
	C	170÷186	205÷221	C	78	94
	A	130÷142	157÷169	A	112÷120	135÷143
	B	181÷189	219÷227	B	181÷189	219÷227
	C	98	117	C	116÷120	139÷143
	A	94÷98	113÷117	A	76	91
	B	181÷189	219÷227	B	181÷189	219÷227
	C	134÷142	161÷169	C	152÷164	183÷195
	A	130÷142	157÷169	A	112÷120	135÷143
	B	199÷211	241÷253	B	199÷211	241÷253
	C	78	94	C	98	117
	A	130÷142	157÷169	A	112÷120	135÷143
	B	199÷211	241÷253	B	199÷211	241÷253
	C	78	94	C	98	117

TAB. 5

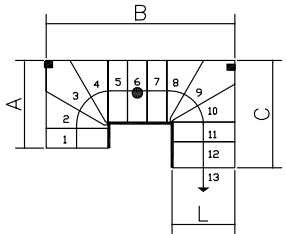
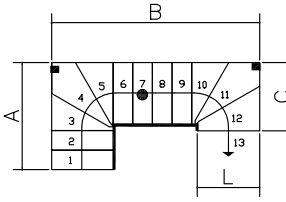
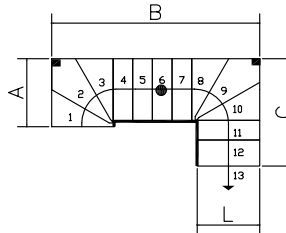
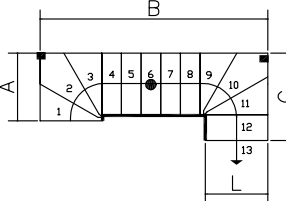
	cm			cm		
	L=74	L=89		L=74	L=89	
	A	94÷98	113÷117	A	76	91
	B	199÷211	241÷253	B	199÷211	241÷253
	C	116÷120	139÷143	C	134÷142	161÷169
	A	112÷120	135÷142	A	94÷98	113÷117
	B	217÷233	263÷279	B	217÷233	263÷279
	C	78	94	C	98	117
	A	76	91	A	94÷98	113÷117
	B	217÷233	263÷279	B	235÷255	285÷305
	C	116÷120	139÷143	C	78	94
	A	76	91	A	76	91
	B	235÷255	285÷305	B	253÷277	307÷331
	C	98	117	C	78	94

